

APEX^{3R} CNC Router

The Next Generation of CNC Routers

MultiCam's flagship Apex3R CNC Router sets the standard for routing capabilities as it is the perfect balance of performance and precision. With cut speeds up to 1,950 inches per minute (IPM), the Apex3R offers world class motion, speed, and cut quality.

Designed for a wide range of applications, the Apex3R is the perfect solution for companies looking for both value and high performance in a CNC Router.



Base Frame

Solid Heavy-Duty Construction

The Apex3R's base is a rigid 3/8" thick tube frame that is welded, stress-relieved, and precision machined. It provides a heavy and accurate platform that translates into gentle motion for clean, smooth cuts.



Helical Rack & Pinion

Smooth Motion, Minimal Friction

Helical racks are standard on the Apex3R and coupled with 25mm rail provides smooth, accurate motion across any size table.



Steel Gantry & Cast Steel Risers

Custom Engineered for Maximum Rigidity

All cast steel riser with 3/8" gantry tube steel precision machined to work together allowing users to cut a higher speeds for optimum edge quality.



Digital Servo Drives

Accurate & Reliable

Digital servo drives and brushless digital AC servo motors for a digital vector servo drive system are standard on all Apex3R machines.



Spindle Options 24K RPM to 32K RPM

Multiple manual and ATC spindle options to cover any cutting application. Higher horse power spindle options for large tooling, higher chip load on dense materials and high RPM's for supreme edge finish pass cutting.

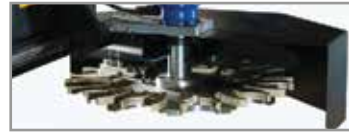

Spindle ATC Linear/Rotary Options

Having multiple spindle tools for various cut processes is no problem for the Apex3R to automatically pick up tools from a 12 position rotary tool changer as well as options of single or dual linear rack.



Single or Dual Knife Pneumatic & Oscillating Options

There is an amazing list of materials that can be easily cut using our different knife options of pneumatic or electric knife and several quick change drag knife holders.

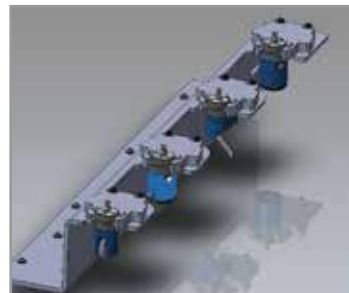

KTC Knife Tool Changer

The automatic knife changer rack sets the machine up for a variety of operations which increases productivity and operator safety. Automatically picking up the correct knife reduces operator error, saving time and material costs.

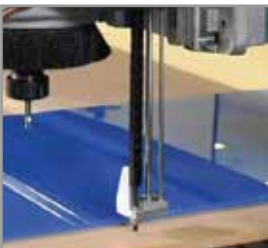

Surface Probe & Calibration Sensor Easy & Hands Free

Reduce machine setup time with this automated hands free option. Easily set tooling lengths and material work surface accurately.



Active Dust Boot Keep Your Workplace Clean

Automatically having the dust boot change position to maintain dust bristles at surface of material regardless of different tool lengths of depth of cut allows for maximum particulate pick up.

Options:

Laser Pointer – easily set soft home on material

Pop-Up Pins – one man load

Mister

Manual or Pneumatic Vacuum Zones

Dust Collection Systems with Duct Work

Tooling Kits



MultiVision

Dynamic Digital Registration

MultiVision provides additional flexibility by visually recognizing media registration marks and automatically compensating for skew and image drift.



EZ Control

Powerful, Intuitive Control

MultiCam's EZ Control provides all users, from novice to advanced, with the most powerful and easy-to-use control system available on today's market. New operators can be productive in as little as an hour!

Specifications	Inches	Metric
*Max Material Thickness	4-5"	101.6-127mm
Gantry Height	6", 8"	152.4mm, 203.2mm
Cutting Speed	1950 IPM	825.5 mm/sec
Rapid Traverse	2758 IPM	1167.6 mm/sec
Repeatability	+/-0.001"	+/-0.025mm
Drive System (X,Y)	Helical	Helical
Drive System (Z)	Ball Screw	Ball Screw
Standard Work Surface	1" Phenolic	25.4mm Phenolic

Specifications subject to change without notice.

*Stock machine comes with standard 6" gantry clearance.

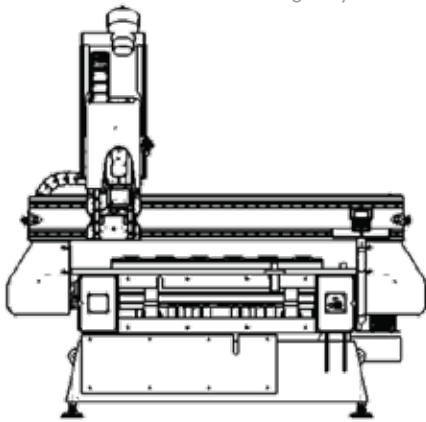

*Model	Inches	Metric
103	53" x 100"	1346mm x 2540mm
204	63" x 121"	1600mm x 3073mm
304	83" x 121"	2108mm x 3073mm

*Other sizes available

Table available with manual or pneumatic vacuum zones.

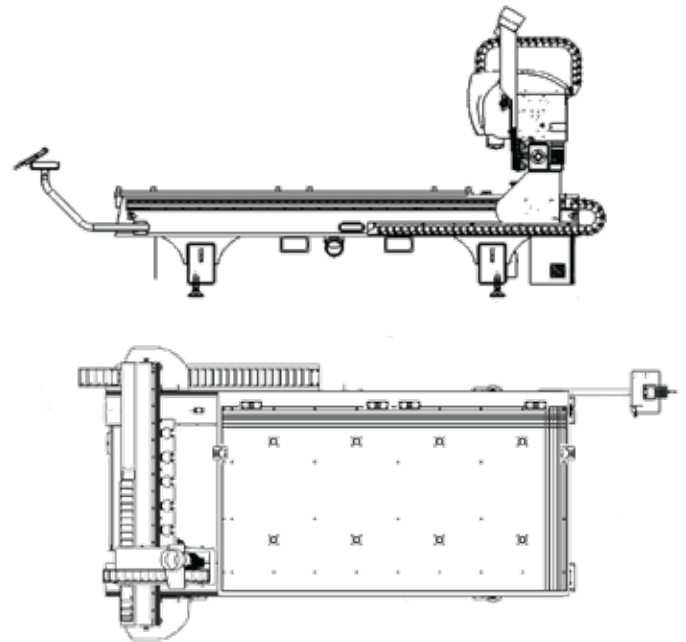

ARROW DIGITAL PVT. LTD.



1005-1006, Aditya - 10th Floor, Opp. Sardar Patel Seva Samaj, Off. C G Road, Mithakhali, Navrangpura, Ahmedabad - 380006. Gujarat - India.

Tel.: +91 79 26404017 / 18, +91 79 26405048 / 49

Demo Center - Ahmedabad

Branches : Ahmedabad, Bengaluru, Delhi, Indore, Kolkata, Mumbai, Pune, Surat

www.arrow-digital.com

sales@arrow-digital.com