



# APEX<sup>1R</sup>

CNC Router

## Maximum Flexibility, Made Affordable

MultiCam heard the industry challenge and has built the first fully capable, turnkey CNC solution at an affordable price! This rigid and reliable servo driven machine has four spindle options and either a single or dual tangential knife option. Both the spindle and knife are perfectly suited to cut a multitude of materials with unsurpassed performance and cut quality.



### Base Frame

**Solid Heavy-Duty Construction**

A solid-steel frame design is standard on the Apex 1R. It provides a heavy and accurate platform that translates into gentle motion for clean, smooth cuts.



### Servo Drive System

**Smooth & Accurate**

The Apex 1R, comes standard with a Robust Drive Motor system with Servo Drives to allow for powerful yet fluid motion.



### Router Spindle

**Multiple Spindle Options Up To 10HP, 24K RPM**

The Apex 1R comes equipped with a high-frequency spindle for optimal durability when cutting thin or dense materials.



### Linear ATC

**Automatic Tool Changer**

The ATC spindle offers a linear rack for spindle or knife pickup locations. Automatic spindle tool pickup rack is a high value yet low cost option. (4-14 locations based on width of machine)



**Helical Rack**  
Smooth Motion, Minimal Friction

Helical racks are standard on the Apex 1R and provide smooth and accurate motion as the gantry moves through all axes.



**Tangential Knives**  
Enhanced Cutting Capabilities

The single or dual knife system expands the cutting capabilities of the Apex 1R by allowing a wide range of materials to cut with electric oscillating or the automatic quick change drag knife attachments.

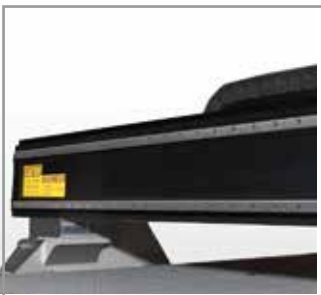

**Gantry**  
Custom Engineered for Maximum Rigidity

MultiCam engineered the gantry from steel tube that is precisely machined for maximum rigidity at the spindle tool, providing users with optimum edge quality.



**4 Zone Vacuum Work Surface**  
Manual or Pneumatic Valves

Optimize vacuum hold down using 4 zoned milled phenolic work surface grid pattern to accept custom gaskets for better vacuum control. Upgrade to pneumatic valves for enhanced workflow and saving time.



**EZ Control**  
Powerful, Intuitive Control

MultiCam's EZ Control provides all users, from novice to advanced, with the most powerful and easy-to-use control system available on today's market. New operators can be productive in as little as an hour!



**Computer Workstation**  
Easy Operations Interface

Adjustable ergonomic stand with an all-in-one 24" PC pre-loaded with Coreo machine software. Upgrade to full CAD/CAM suite for efficient streamlined at machine workflow.

**Options:**

MultiVision

Laser Pointer – Easily set soft home on material

Mister for cutting non-ferrous metals

Barcode Scanner

Automatic Quick Change Knife and Oscillator

Dust Collection System

Light Workstation with 24" Computer



**MultiVision**  
Dynamic Digital Registration

MultiVision provides additional flexibility by visually recognizing media registration marks and automatically compensating for skew and image drift.



**Laser Pointer**  
Decrease Job Set-Up Times

Quickly and accurately identify reference points on the material to minimize job set-up time.

Specifications	Inches	Metric
Max Material Thickness	3"	76.2mm
Repeatability	+/-0.001"	+/-0.025mm
Cutting Speed	1300 IPM	550.33 mm/sec
Rapid Traverse	1900 IPM	804.3 mm/sec
Drive System (X,Y)	Helical	Helical
Drive System (Z)	Ball Screw	Ball Screw
Standard Work Surface	1" Phenolic	25.4mm Phenolic

Model	Inches	Metric
103	48" x 96"	1219mm x 2438mm
204	60" x 120"	1524mm x 3048mm
304	83" x 121"	2108mm x 3073mm

\*Other sizes available

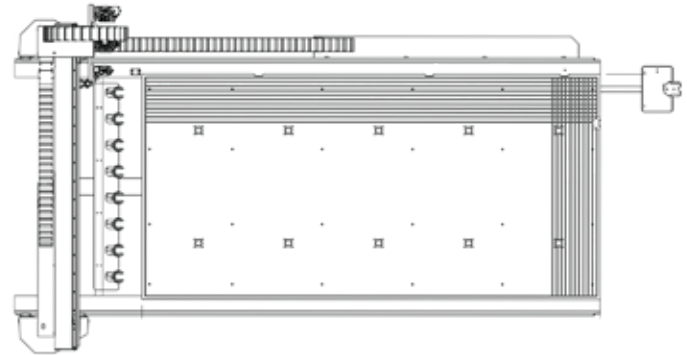
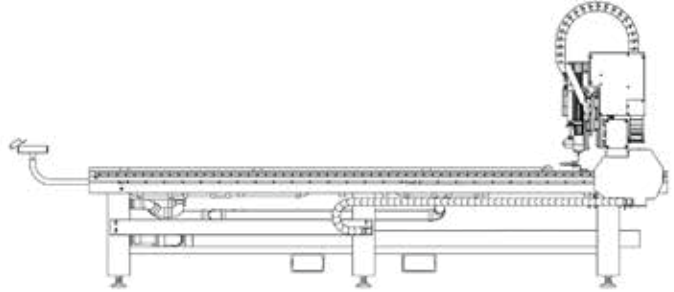
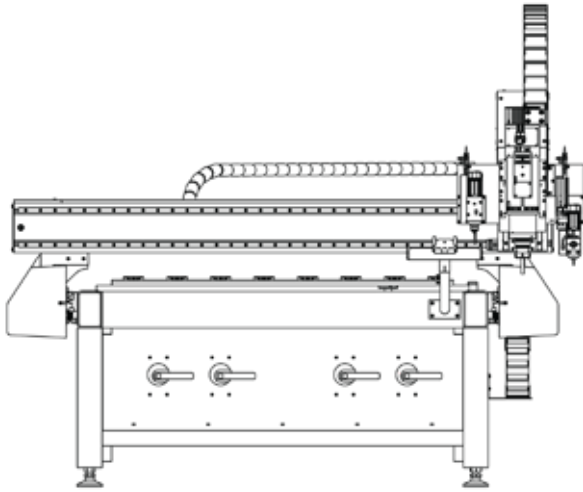

ARROW DIGITAL PVT. LTD.



1005-1006, Aditya - 10<sup>th</sup> Floor, Opp. Sardar Patel Seva Samaj, Off. C G Road, Mithakhali, Navrangpura, Ahmedabad - 380006. Gujarat - India.

Tel.: +91 79 26404017 / 18, +91 79 26405048 / 49

Demo Center - Ahmedabad

Branches : Ahmedabad, Bengaluru, Delhi, Indore, Kolkata, Mumbai, Pune, Surat

[www.arrow-digital.com](http://www.arrow-digital.com)

[sales@arrow-digital.com](mailto:sales@arrow-digital.com)